

# V65e

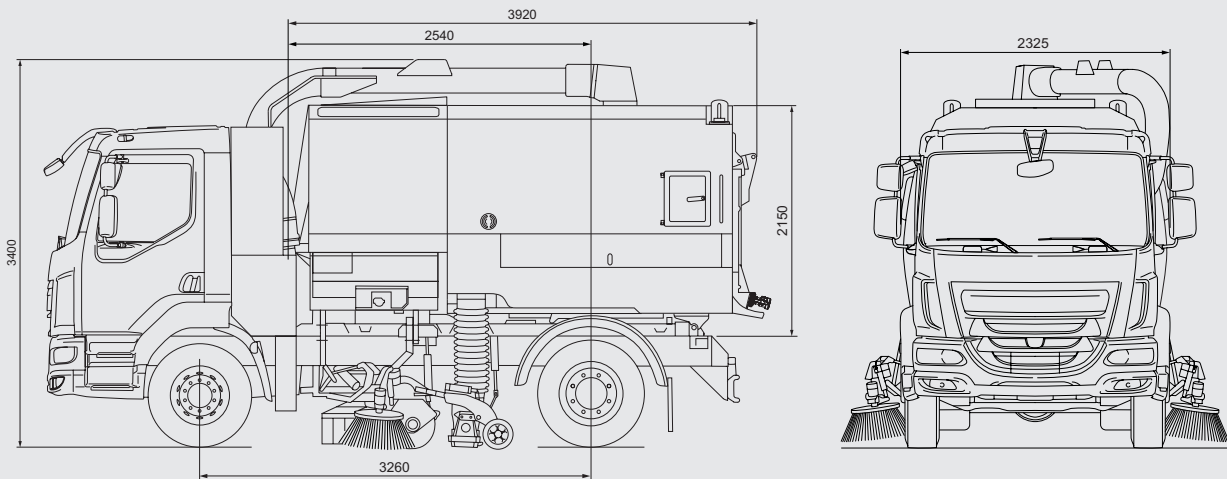

### Dimensions

Length (cowl and hopper)	3920 mm
Width	2325 mm
Height	3400 mm
Wheelbase	3260 mm
Sweeping path of suction nozzle and channel brush	1300 mm
Sweeping path with roller brush	2400 mm
Sweeping path for double-sided pick up	3600 mm

### Noise level cab

< 75 dB(A) generally (dependent on chassis)

### Chassis

GVM 16 tonnes

### Battery Data

Type	Lithium-Ion Ferro Phosphate (LiFePo4)
Voltage (Nominal)	600 V
Capacity	200 kWh
Sweeping Range	up to 8 hours - EN15429-2
Transit Range	200 km

### Charging System

Charging Cycles	2000
Charging Socket	Type 2
Charge Cable Options	
	63 A 5 Pin 3-Phase - Charge time - 4 - 5 hrs
	32 A 5 Pin 3-Phase - Charge time - 8 - 9 hrs

## V65e



### Charging

32A or 63A 3 Phase 5 Pin Type 2 charging cables are available with onboard storage provided.



### JVM Screen

With colour 7" screen providing fault diagnosis and operational feedback and operator preferences.

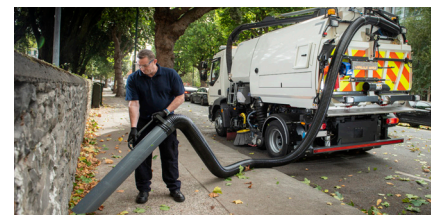

### Littasnatch

A rear lightweight rear door mounted litter hose with air operated gate for the collection of litter up to 7 metres away from the sweeper.

# V65e

## Controls

Centre cab mounted master control panel with JVM providing information on a wide range of sweeper functions plus data capture download. Up to four optional cameras can also be viewed on the JVM screen. Separate palm rest controller housing controls for the main sweeping functions is mounted on the door side.

## Exhauster fan

Operational speed variable between 1500 rpm - 3600 rpm to suit operation.

## Channel brush

Quick release brush system with infinitely variable speed up to 160 rpm (cab controlled). Hi-visibility yellow brush plate and hose guide.

## Nozzle

Cast aluminium nozzle with 250 mm diameter inlet and tool free adjustment.

## Dust suppression system

Dust suppression sprays located at suction nozzle(s), channel brush(es) and across front of vehicle. Pressadrain water purging system. EUnited PM10 4\* Certified.

## Electrical system

600V High Voltage System with orange high voltage cables. Full electric drive for Suction Fan (and Supawash option) with electric motor driving hydraulic motors for the sweepgear. On-board 44 kW charger.

## Exterior noise / Sound power level

LWA 108 dB(A) measured in accordance with EC directive 2000/14/EC.

## Hopper

Body comprises of hopper & integral water tank. Fabricated from heavy duty stainless steel plate. Water tight twin lock rear door latching system with de-watering function. Two body side access doors and side storage lockers. Plug in hopper floor as transfer port for use as Streetwasher. Rear discharge chute, automatic multi position body prop, twin caged rear beacons and LED worklights are standard features.

Hopper voided volume ***	6.5 m <sup>3</sup>
Discharge angle	54° nominal
Door opening angle	125° nominal

## Water tank

Water tank incorporates anti-surge baffles and filled via a type 'A' water hydrant fill. A twin diaphragm pump runs continuously and is able to run dry.

Water capacity (option 2000 l) 1554 l

## Cowl

Smoothflow cowl lined with frequency matched soundproofing material.

## Brushes

Wide sweep brush	Ø 406 mm
Width of roller brush	1275 mm
Width of suction nozzle	750 mm
Channel brush	500mm (opt. Ø 650 mm)

## Options

- Camera monitoring systems.
- Littasnatch.
- Microtrap dust suppression system.
- Powathrust/Powasave.
- Pneumatic mesh shakers.
- Powascrub - wide sweep brush ground pressure device.
- Supawash - high pressure washing system (32 l/min @ 100 bar), c/w Handlance, reel, 15m hose. Also available with nozzle spraybars.
- 6" boom mounted Wanderhose with power assist option.

A range of options are available – contact us for more information.

Subject to change without notice.

\*\*\* All Bucher Municipal Hopper Capacities are measured in accordance with European Standard EN 15429.



## Bucher Municipal Ltd

Curtis Road, Dorking  
Surrey RH4 1XF  
Tel: +44 (0)1306 884722  
Fax: +44 (0)1306 884151  
info.uk@buchermunicipal.com

www.buchermunicipal.com



Bucher  
Municipal  
E-Shop

Driven by better