

Bucher CityCat VR50e

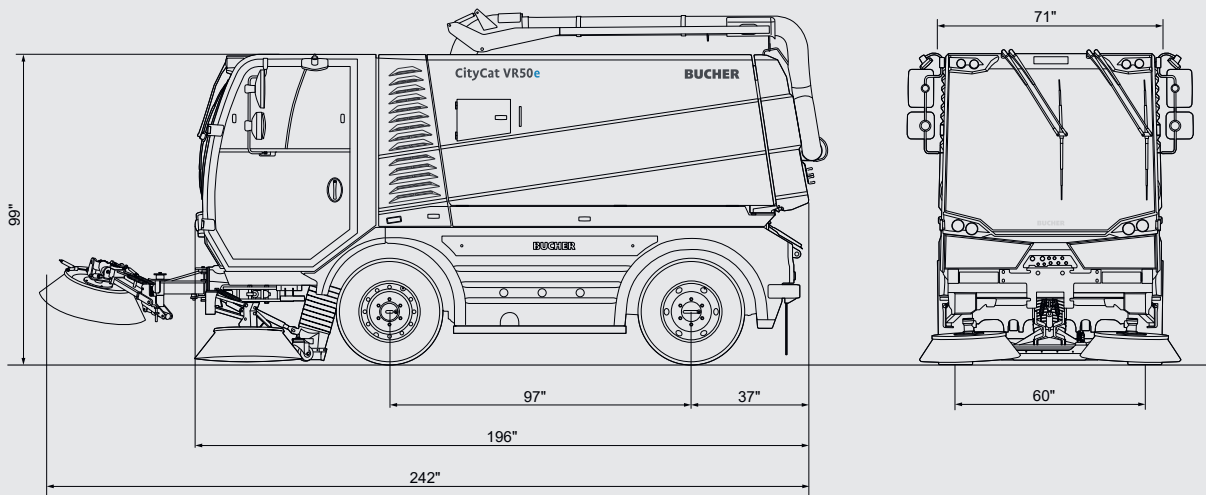

Dimensions

Length	196"
Width	71"
Height	99"
Wheelbase	97"
Track width	60"
Cleaning width 2 brushes	99"
Cleaning width 3 brushes	138"
Turning radius	116"

Tires

265 / 70 R 19.5 140 / 138M

Driving Performance

Working speed	0-12 MPH
Travelling speed	0-31 MPH*
Climbing ability	up to 30 %

Noise level cab

63 dB(A)

Chassis

Bucher fabricated ladder frame chassis with "C" Rail construction

GVW	23,200 lbs
Empty weight	12,800 lbs
Payload	10,400 lbs

HV Battery

Battery type	Li-ion
Battery capacity	137 kWh
Nominal voltage	573 Volt
Operating time	up to 10 hours

Charging system

On-board charger	22 kW
Charging time	5 to 6 hours
External charger DC ¹	70 kW
Charging time	1.5 to 2 hours

* According to national legislation

¹ Option

Bucher CityCat VR50e: performance package in the compact class



Charging anywhere, anytime

Charging with both AC 22 kW and DC 70 kW allows full flexibility and customization to individual needs. From single shift to multiple shifts, and charging times of up to two hours.



Choose your settings

The CSense display (10.1 inch touch display) with intuitive design for extended functions, central overview of all settings and visual diagnostic system. The displayed vehicle set-up can be individually chosen by the driver.

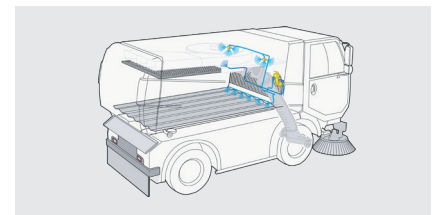

EasyClean System

The operator simply activates the EasyClean self-cleaning function. The blower, filter screen, dirty water tank, side walls and other difficult to reach pockets of dirt are then sprayed by the cleaning nozzles. The machine is perfectly clean within a couple of minutes.

Bucher CityCat VR50e

Steering

Hydrostatic controlled 4 wheel steering.

Axles

Drive-axle at the rear with differential and planetary hub reduction. Running axle at the front.

High capacity battery Pack

Battery pack with 137 kWh. This guarantees an outstanding autonomy with an operating time of up to 10 hours with a single charge. The exceptionally robust and maintenance-free design provides a long service life and a minimized battery aging.

Charging System

Two charging systems for all situations

Internal Charger	22 kW
Charger Inlet	Type 2
Charging time 137 kWh	5 - 6 hours
External Charger DC	70 kW
Charging Inlet	CCS Combo 2
Charging time 137 kWh	1.5 - 2 hours

Brakes

Hydraulic, dual-circuit high performance brake system with double callipers on each side on front axis and single calliper on rear axis. Manually operated parking brake, acting hydraulically on additional brakes disc ahead of differential.

Driver's cab

Comfortable, hydro bearing suspension, soundproofed cab. Windscreen made of heat-insulating, curved, low-reflection safety glass. 2 sliding windows in each door. Multi-speed heating fan. Sun visor. Windscreen wiper/washer system Air-sprung driver's seat and sprung passenger's seat, each individually adjustable. Steering column can be adjusted in both the angle and height.

CSense display

(10.1 inch touch display) with intuitive design for extended functions, central overview of all settings and visual diagnostic system. The displayed vehicle set-up can be individually chosen by the driver.

Pick-up system

Pick-up principle based on suction, with retracted, rust-proof suction nozzle in front of axis, can be hydraulically moved 15" laterally with the side brush. Hydraulic suction nozzle height adjustment. Stepless adjustable high-power suction fan.

Hopper

Volume	7.3 yd ³
Hydraulic tipping and opening.	
Dumping height, low dumping	37"
Dumping height, high dumping	61"
Dumping width	67"
Tipping angle	51 °

Water system

Water capacity	232 gallons
2 water pumps for water nozzles.	

Brushes

2 side brushes left and right	Ø 35"
Impact-proof brush suspension - impact protection	
3rd front brush on Type XL for maximum cleaning width of 138", can be used left and right	
Variable speed adjustment	0-150 rpm

Options

- Air conditioning
- External Charger DC 70 kW
- Additional water tank 295 gallons (total 528 gallons) - reduces hopper volume
- Boom with reel and hand lance
- 1,450 PSI or 2,900 PSI water pump
- High dump
- Water recirculation system
- Wander hose
- Weed brush
- Hydraulic tilt of the side brushes
- Water flushing bar
- High pressure water system
- EasyClean system
- Gutter guard lifting gear
- LED work light
- Rear view and suction nozzle camera

A variety of other options are available – contact us for more information.

Scan for your free report



The 5 Things You Must Know Before Buying a Street Sweeper

Bucher Municipal North America, Inc.

105 Motorsports Road
 Mooresville, NC 28115
 Phone: 704-658-1333

www.buchermunicipal.com/us/en

Driven by better



Version 02_06/27/2022
 Technical data is subject to change without prior notice.
 The illustrations may deviate from standard equipment.