

# Bucher CityCat W20e

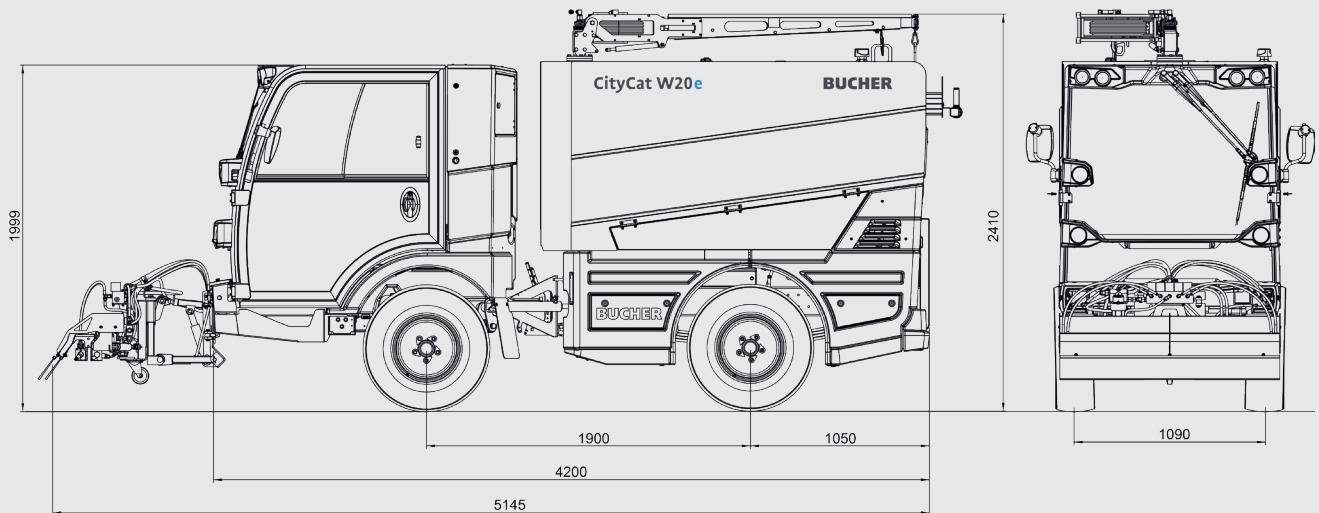

## Dimensions

Length	4200 mm
Width	1300 mm
Height	1999 mm
Height with boom	2410 mm
Wheelbase	1900 mm
Track width	1090 mm
Cleaning width min.	1300 mm
Cleaning width max.	2400 mm

## Weight

Empty weight	2700 kg <sup>1</sup>
Payload	2100 kg <sup>1</sup>
GVW	4800 kg

## Emissions

Noise level L <sub>WA</sub>	92 dB(A)
-----------------------------	----------

## Tyres

215/75 R16 C M+S
------------------

## Drive system

Working speed	0-15 km/h
Travelling speed	0-50 km/h*
Climbing ability	up to 30 %
Electric drive	88 kW
Electric water pump	8.5 kW
Electric hydraulic aggregate	12 kW

## HV Battery

Battery type	Li-ion
Battery capacity	63 kWh / 80 kWh
Nominal voltage	335 Volt
Operating time	up to 10 hours

## Charging system

Internal charger	22 kW
Charger inlet	Type 2
Charging time	2 to 3 hours

\* According to national legislation

<sup>1</sup> Depending on the respective configuration

## Bucher CityCat W20e: the agile compact washer



### Ready for action at any time

The HV battery can be recharged in just two to three hours at any public car charging station thanks to a 22 kW on-board charger.

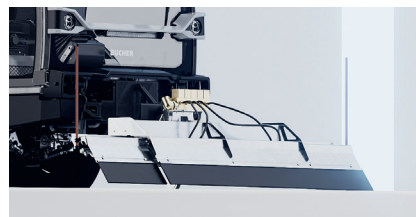

### Telescopic spray bar

The telescopic spray bar is controlled from the cab via the Smart-Con armrest and enables the treatment of areas with a width of 1.3 to 2.4 meters.



### Boom with hose reel and hand lance

The hand lance and water hose with a length of 15 m and an automatic reel are attached to a boom mounted on top of the washer and allow 360° cleaning around the vehicle.

# Bucher CityCat W20e

## Chassis

Two-part ladder-type frame chassis with "C" profile construction. Independent suspension with shock absorber and screw spring on the front axle and leaf suspension with shock absorber on the rear axle.

## Axles and steering

Electrically driven front axle with self-flocking differential gear (Torsen differential gear). Articulated steering with load-sensing steering hydraulics.

## Working hydraulics

Electrically driven hydraulic unit with silent gear pumps for steering, auxiliary functions and operation of the telescopic spray bar.

## Brakes

Hydraulic servo dual-circuit brake system with disc brakes on front and rear axle. Parking brake (spring energy brake) acting on the front axle.

## Cab

Comfortably suspended sound-insulated aluminium cab. Windscreen made of heat-reflecting, curved, low-reflection safety glass. Two sliding windows in each door. Variable heater, sun screens, screen wiper with washer. Individually adjustable, sprung driver's seat with headrest and 3-point safety belt. Angle- and height-adjustable steering column.

## Control unit

Smart-Con operation concept includes a multi-functional armrest with smart start function which makes it possible to operate all working functions with one hand. All relevant information at a glance at any time thanks to the digital 4.3 inch display. CSense display (10.1 inch touch display) with intuitive design for extended functions, central overview of all settings and visual diagnostic system. The displayed vehicle set-up can be individually chosen by the driver.

## Water system

The pump is switched off in case of lack of water. The water is filtered at the filling nozzle, before the pump and with a high pressure filter before the spray bar. Pressure adjustable from the cab.

Max. flow rate	70 l/min
Max. pressure	60 bar
Drive	electric motor

## Hopper

Water tank with baffles and an access hole in the roof of the hopper.

Volume	up to 2000 l
--------	--------------

## Washing system

The telescopic spray bar can be used over a working width of 1.3 to 2.4 meters and is hydraulically swiveled, raised, lowered, and extended and retracted. The spray bar consists of 5 segments which can be switched on and off individually. These are the central spray bar, the extendable spray bars as well the side flushing nozzles on the right and left.

## Boom with hose reel and hand lance

The boom is equipped with an automatic hose reel and a hand lance mounted on the roof of the hopper. It can be rotated 360° without restriction and is supported on gas pressure cylinders.

Radius boom arm	2003 mm
Range of operator	13.5 m

## Options

- Air conditioning
- Radio with Bluetooth & DAB+
- High pressure water system
- Detergent injection
- Flags for telescopic spray bar
- LED work lights

A variety of other options are available – contact us for more information.

## Bucher Municipal



For local contact and support, please scan the QR code or visit

[buchermunicipal.com](http://buchermunicipal.com)

