

R65m

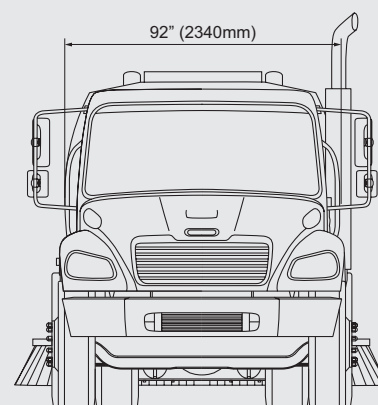
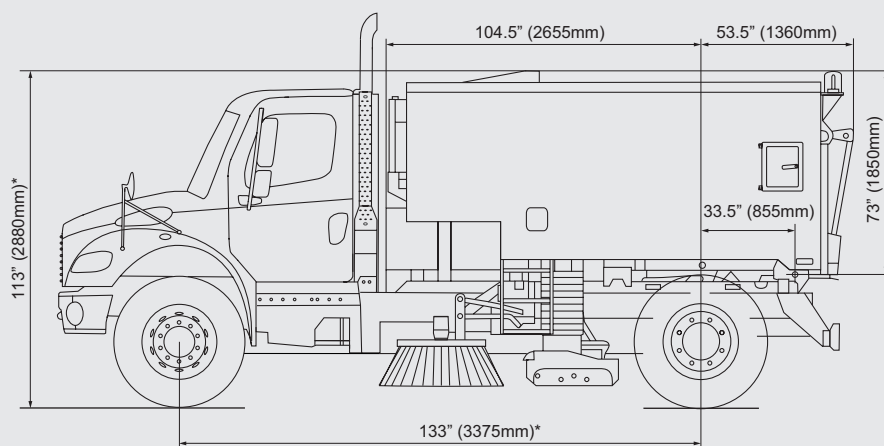

Dimensions

Length (cowl and hopper)	158" (4015 mm)
Width	92" (2340 mm)
Height*	113" (2880 mm)
Wheelbase*	133" (3375 mm) nominal

Noise level cab

<75 dB(A) generally (dependent on chassis selection).

Chassis

GVM	(Up to 33,000 lbs) 13-15 Tonnes
Gearbox	Allison 3500 RDS
Rear Axle	6.50/8.87
Tyres	11R22.

* Dependent on chassis and/or option selected

R65m



Gutterbroom Extension Override

allowing variable positioning of the gutterbrooms from in the cab by overriding the extended position.



Rear Mounted Wanderhose

for gully suction and drain clearance with pendant control to aid the operator.



Wireless pendant

allowing the operator to walk around the sweeper and check surroundings before opening the hopper or tipping.

R65m

Controls

Centre cab mounted master control panel with JVM providing information on a wide range of sweeper functions plus data capture download. Up to four optional cameras can also be viewed on the JVM screen. Separate palm rest controller housing controls for the main sweeping functions.

Exhauster fan

Heavy duty, dynamically balanced impeller with multivane corrosion resistant blades. Operational speed between 2400 and 3000 rpm drive via a Hydraulic Motor.

Gutter brooms

Large 1100mm, hydraulic driven, leading arm, digger type, free floating gutter brooms with in-cab adjustable speed and down pressure insure aggressive cleaning of curbs and gutters.

The Gutter brooms feature a heavy duty steel disc, drilled for either four or five segment broom sections. The broom material is tempered steel tines, 650mm long.

At the operator's discretion, from in-the cab, the dual brooms can extend out to achieve a 3550mm total reach to facilitate cul-de-sac and curve sweeping.

Pick up hood

Low noise suction system with 350mm (14") diameter suction and blast hoses.

Dust suppression system

Dust suppression sprays located at the pick up hood, channel brush(es) and across the front of the pick up hood.

Pressadrain water purging system.

Electrical system

12 volt only.

All external loom connections are full automotive IP67 rated.

Exterior noise / Sound power level

L_{WA} 110 dB(A) for standard power engines measured in accordance with EC directive 2000/14/EC.

Hopper

Body comprises of hopper & integral water tank. Fabricated from heavy duty stainless steel plate. Single lock rear door latching system with de-watering function.

Rear discharge chute, twin rear caged beacons. Automatic body propping mechanism.

Hopper voided volume** (8.5 yd³) 6.55 m³

Discharge angle 55° nominal

Door opening angle 125° nominal

Filter mesh area 1.60 yds² (1.21 m²)

Water system

Water tank incorporates anti-surge baffles and filled via a type 'A' water hydrant fill.

A twin diaphragm pump runs continuously and is able to run dry.

Water capacity 300 GAL (1100 l)

Dust spray pump output Up to 9.2 US gal (35 l/min)

Dust spray water pressure 51 psi (3.5 bar)

Water tank Capacity 300 gal (1100 litres)

Options

- Camera monitoring system.
- Hydrant layflat hose.
- Pneumatic mesh shakers.
- Rear mounted Wanderhose, 8 inch, hydraulically powered.
- Rear mudflaps.
- Rotatilt (with auto flatten).
- Supawash - high pressure washing system.
- Handlance, slim hose reel, and front spraybar
- Rear LED Work lights.
- Bonded Intake Duct.
- Additional 700 litre water tank.
- Mesh shakers, air operated cleaning system.

A range of options are available – contact us for more information.

** All Bucher Municipal Hopper Capacities are measured in accordance with European Standard EN 15429.

Subject to change without notice.



Bucher Municipal

For local contact and support visit

www.buchermunicipal.com