

# Bucher Recycler CR80

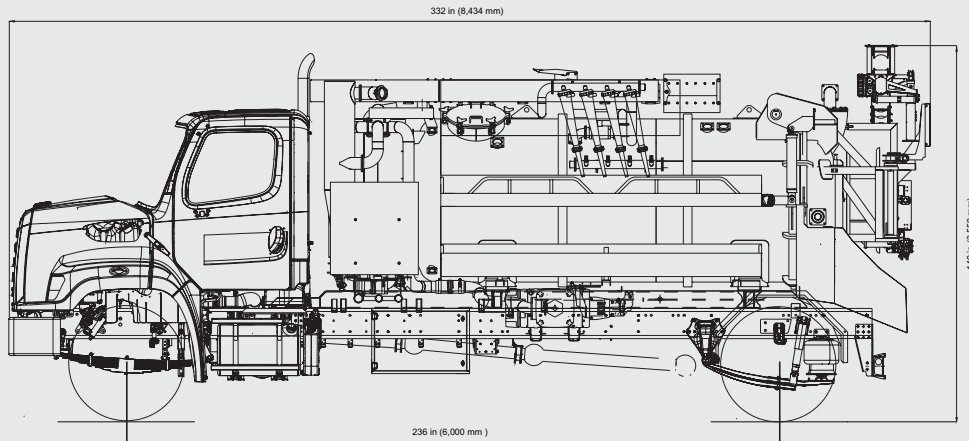

## Dimensions and weight

Length	332 in (8,434 mm)
Width	100 in (2,550 mm)
Height	140 in (3,550 mm)
Wheelbase	236 in (6,000 mm)
GVW	40,000 lb (19,504 kg)
TARE weight	Approx. 28,130 lb (12,760 kg)

## Transmission

Power take-off	From engine and/or gearbox
Jetting pump	Hydraulic driven
Vacuum pump	Hydraulic driven

## Engine

Type	Detroit DD8 7.7 L
Horse power	330 HP
Fuel	Diesel

## Chassis

Freightliner	M2 106 4X2
Cab type	106" BBC Flat roof aluminium conventional cab
Mudguards	Aluminium

## Finish

Undercarriage and components	Grey
Cabin and tank	White
Cabinets and shelves	Painted
Sign plates	3 pcs.
Text and stripping	Invoiced separately

## Water Recycling system

Pump	DOA WP25
Operation	Hydraulic
Connection/Coupling	2" / Camlock
Filter system	Coarse and fine filters
Recycling	5-step, automatic, continuous

## The market's most powerful recycling system



### Control panels

Set up, operate and adjust all functions with the control panels.



### Double telescopic arm

Reach longer and operate with less disturbance for passersby.



### Continuous recycling system

Save resources while increasing productivity and sustainability.



### Cabinets and Shelves

Store your gear in the shelves and lockable cabinets.

# Bucher Recycler CR80

## Tank

Volume	8 yd <sup>3</sup> (6 m <sup>3</sup> )
--------	---------------------------------------

Operating pressure	7.2 psi (0.5 bar)
--------------------	-------------------

End cover	Hydraulic, fully automatic
-----------	----------------------------

A pneumatically moved partition divides the tank in two variable sizes keeping sludge and water separated.

Locking bolts	2 set, pneumatic
---------------	------------------

Tank level indicator	2, sludge & water
----------------------	-------------------

Suction valves top	4", pneumatic
--------------------	---------------

Suction valves bottom	4", manual
-----------------------	------------

Water filling valve	2", Camlock
---------------------	-------------

## High-pressure system

Pump model	Uraca P3-15
------------	-------------

Pump capacity	55 gpm @ 2,320 psi (207 l/min @ 160 bar)
---------------	---

Jetting hose reel	Hydraulic
-------------------	-----------

Hose size	¾" 492 ft (150 m)
-----------	-------------------

Hose material	Plastic
---------------	---------

## Vacuum system

Pump model	CVS VacuStar 1300
------------	-------------------

Pump capacity	765 cfm (21,667 l/min) @ free flow
---------------	---------------------------------------

Max. vacuum	26,6 inHG (90%)
-------------	-----------------

Suction cassette	Hydraulic
------------------	-----------

Suction hose diameter	4"
-----------------------	----

Telescope extension	7 ft (2 m)
---------------------	------------

Coupling	Camlock
----------	---------

## Controls

Controller	CAN-BUS
------------	---------

Control remote	1 pcs.
----------------	--------

Control panels	3 pcs.
----------------	--------

## Storage

Cabinets, double	1 pcs.
------------------	--------

Comfort cabinet	Inside double cabinet. Warm water, mirror, soap, paper holder.
-----------------	---

Tool cabinets	1 pcs.
---------------	--------

Hose shelves	2 pcs.
--------------	--------

Tool shelves	2 pcs.
--------------	--------

## Lights

Work lamps	5 pcs., LED
------------	-------------

Beacons	4 pcs., LED
---------	-------------

## Accessories

- One nozzle set
- One vice
- One end cover safety support

Contact us for more information.

*Subject to change without notice.*

## Bucher Municipal North America Inc.

Motorsports Road 105  
NC-28115 Mooresville  
Tel. +1 704 658 1333  
Fax +1 704 658 1377  
info.bmna@buchermunicipal.com

[www.buchermunicipal.com](http://www.buchermunicipal.com)