

# Bucher Recycler CR150

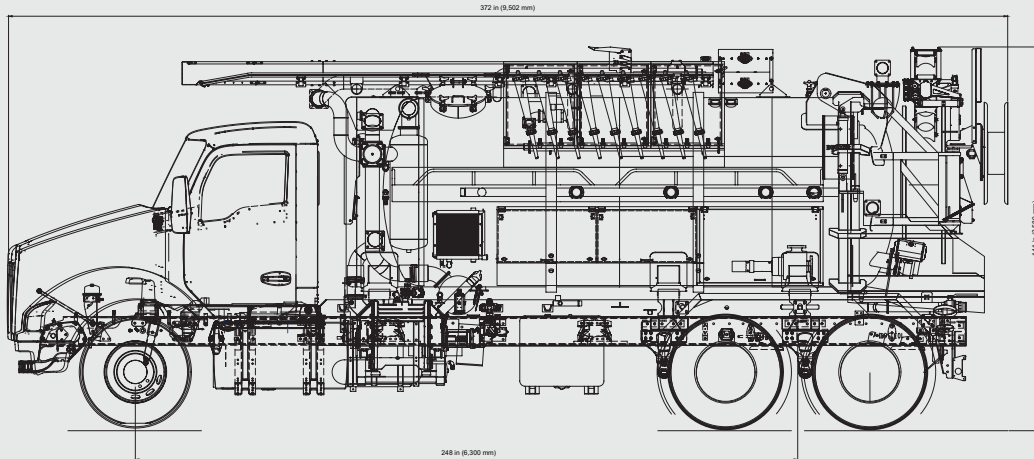

## Dimensions and weight

Length	372 in (9,502 mm)
Width	102 mm (2,580 mm)
Height	141 in (3,580 mm)
Wheelbase	248 in (6,300 mm)
GVW	66,000 lbs (29,937 kg)
TARE weight	Approx. 43,078 lb (19,540 kg)

## Transmission

Power take-off	Semi hydraulic
Jetting pump	Belt driven
Vacuum pump	Hydraulic driven

## Engine

Type	ISX12 425V
Horse power	425HP
Fuel	Diesel

## Chassis

Kenworth	T880 6X4
Cab type	Day cab
Rear view camera	Yes
Mudguards	Aluminium

## Finish

Undercarriage and components	Black
Cabin and tank	White
Cabinets and shelves	Painted
Sign plates	3 pcs.
Text and stripping	Invoiced separately

## Water Recycling system

Pump	Desmi S80
Operation	Hydraulic
Connection/Coupling	2" / Camlock
Filters	Coarse and fine filters
Recycling	5-step, automatic, continuous

## The market's most powerful recycling system



### Control panels

Set up, operate and adjust all functions with the control panels.

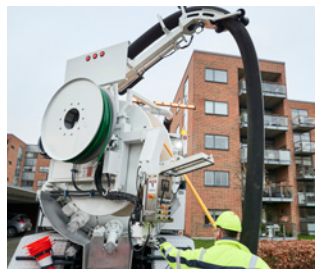

### Double telescopic arm

Reach longer and operate with less disturbance for passersby.



### Continuous recycling system

Save resources while increasing productivity and sustainability.



### Cabinets and Shelves

Store your gear in the shelves and lockable cabinets.

# Bucher Recycler CR150

## Tank

Volume	15.7 yd <sup>3</sup> (12 m <sup>3</sup> )
Operating pressure	14.5 psi (1 bar)
End cover	Hydraulic, fully automatic

A pneumatically moved partition divides the tank in two variable sizes keeping sludge and water separated.

Partition positions	3, fixed
Locking bolts	3 sets, pneumatic
Tank level indicator	2, sludge & water
Suction valves top	4", pneumatic
Suction valves bottom	6", pneumatic
Water filling valve	2", manual

## High-pressure system

Pump model	Uraca P3-45
Pump capacity	124 gpm @ 2,175 psi (471 l/min @ 150 bar)
Jetting hose reel	Hydraulic
Hose size	5/4" 656 ft (200 m)

Hose size	3/4" 164 ft (50 m) + 1/2" 196 ft (60 m)
Meter counter	Yes
Hose guide	Yes

## Vacuum system

Pump model	CVS WR 3100
Pump capacity	1,825 cfm (51,667 l/min)
Max. vacuum	25" inHG (85%)
Suction cassette	Hydraulic
Suction hose size	6" (200 mm)
Telescope extension	7 ft (2 m)
Coupling	Camlock

## Controls

Controller	CAN-BUS
Control panels	3 pcs.

## Storage

Cabinets, double	3 pcs.
Comfort cabinet	1 pcs..
Warm water, mirror, soap, paper holder.	
Hose shelves	2 pcs.
Tool shelves	1 pcs.

## Lights

Work lamps	5 pcs., LED
Beacons	4 pcs., LED

## Accessories

- One nozzle set
- One vice
- One end cover safety support

Contact us for more information.

*Subject to change without notice.*

## Bucher Municipal North America Inc.

Motorsports Road 105  
NC-28115 Mooresville  
Tel. +1 704 658 1333  
Fax +1 704 658 1377  
info.bmna@buchermunicipal.com

[www.buchermunicipal.com](http://www.buchermunicipal.com)