

# C202

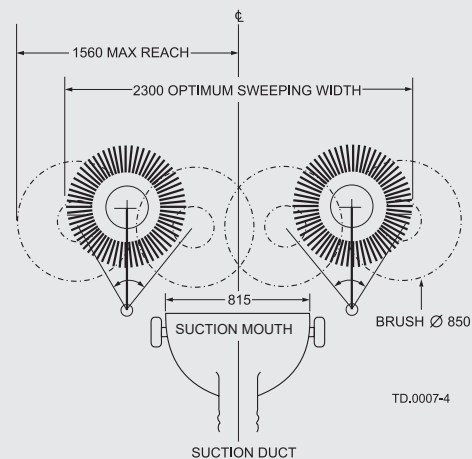
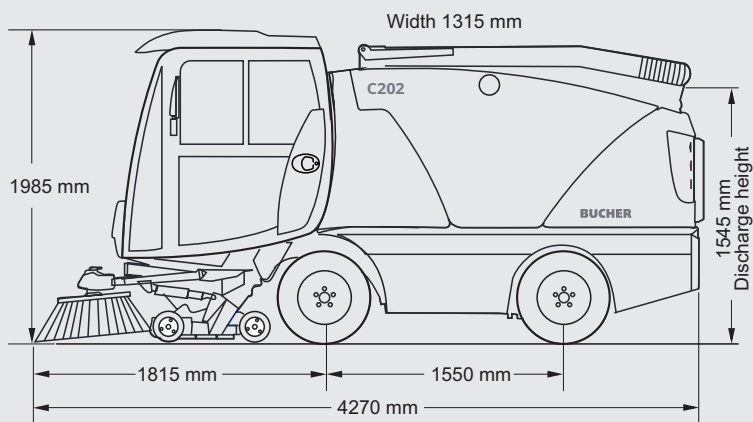

## Dimensions

Length	4270 mm
Width	1315 mm
Height	1985 mm
Wheelbase	1550 mm
Track	1143 / 1158 mm
Max. cleaning width	3120 mm

## Weight

Unladen weight	2850 kg
Payload	1650 kg
GVW	4500 kg

## Tyres (Tubeless)

Front	6.50 R10 Radial
Rear	225/75 R10 Radial

## Drive system

Infinitely variable, hydrostatic drive

## Driving performance

Working speed	0-16 km/h
Travelling speed	0-50 km/h*
Climbing ability up to	30%

## Low emission diesel Engine

Type	R754EU6C / R754ISE5 / R754TE3
Exhaust class	EU 6c / Stage 5 / Stage 3A
Displacement	2970 cm <sup>3</sup>
Output (kW)	62 / 55 / 54
Torque (Nm)	270 / 310 / 255
Fuel tank	52 l
Electrical system	12 V

\* According to national legislation

## C202: small and perfectly formed



### Four-wheel steering

The four-wheel steering ensures maximum directional stability and manoeuvrability. The turning radius is thus 2110 mm (kerb to kerb).



### Brush system

The individually and hydraulically operated side brushes are equipped with a collision shock absorber. The contact pressure control as well as the lifting and tilt adjustment can be adjusted more comfortably from the cab.



### Driver's cab

Daily work is made easier thanks to excellent all-round visibility of the sweeping brushes and the work surface. The floor windows with a direct view of the suction mouth help to ensure efficient and clean sweeping.

# C202

## Electrics

12 volt system with 105 amp alternator.

## Running gear

Four wheel coil spring suspension with Bucher spec gas over oil dampers and a front mounted anti-roll bar.

## Steering

Full hydraulic power steering,  
Turning radius:

2- Wheel steering	
Kerb to Kerb	2610 mm
Wall to Wall	3510 mm

4- Wheel steering (Option)	
Kerb to kerb	2110 mm
Wall to Wall	3265 mm

## Noise

In cab: Noise between 67-75 dB(A),  
depending on operating speed.

External: Under sweeping conditions  
Noise 99 dB(A)

## Brakes

Front: Hydraulic in-board disc brakes with  
dual circuits between front and rear for  
added braking security.

Rear: Hydraulic drum brakes with integral  
parking break.

## Hopper

Stainless steel hopper	1.8 m <sup>3</sup>
Discharge height	1545 mm

Fresh water	152 l (E6c & S5) 175 l (3A)
Recirculation system	250 l

## Cab

Recirculating and fresh air blend heater  
with adjustable vents.

Fully glazed with tinted safety glass.  
Electrically heated "Quick-clear" windscreen.

Fully adjustable air suspension driver's  
seat with adjustable back support. Rigidly  
mounted passenger seat plus 3 point red  
seat belts.

Ergonomically designed for driver comfort.  
Overhead console incorporating lighting  
switches, stereo radio/mp3 player and  
7 inch full-colour screen. A rear console  
containing ignition switch, tipping controls,  
suction fan and water switches. Arm rest  
containing all sweeping related controls  
for brushes, engine speed, brush balance,  
cruise control etc., is ergonomically  
positioned near to the driver.

## Standard machine features

Display System (7 inch full-colour) alerts  
the driver in the event of a system  
problem, also records various data  
which may be downloaded via USB, 'Data  
Capture' feature as standard.  
Independent brush control, Stereo Radio  
MP3 Player c/w USB interface with 45 watt  
dual cone speakers, Reverse Warning:  
Audible warning device with night  
silent override.

## Options

- 4-wheel steering
- Air Conditioning
- Autolube grease system
- CCTV reverse camera system
- Hydrant hose, standpipe & key
- Leaf flap on nozzle for ingestion of leaves
- Nozzle castor wheels
- Radio/CD
- Spare wheel
- Supawash: High pressure washing hand  
lance and pump (9 litres @ 68 bar) c/w  
reel and 10 metre hose.
- Third brush system allowing extended  
swept width.
- Wanderhose: Roof mounted with 3.7  
metre reach.
- Winter Equipment: Snow plough, snow  
broom, rear-mounted gritter/spreader.

A range of options is available - Contact us  
for more information.

*Subject to technical changes without notice.*



## Bucher Municipal AG

Murzlenstrasse 80  
CH-8166 Niederweningen  
Tel. +41 44 857 22 11  
Fax +41 44 857 24 10  
sweepers@buchermunicipal.com

www.buchermunicipal.com



Bucher  
Municipal  
E-Shop

Version 01\_03/2020

**Driven by better**