

Bucher CityFlex C40

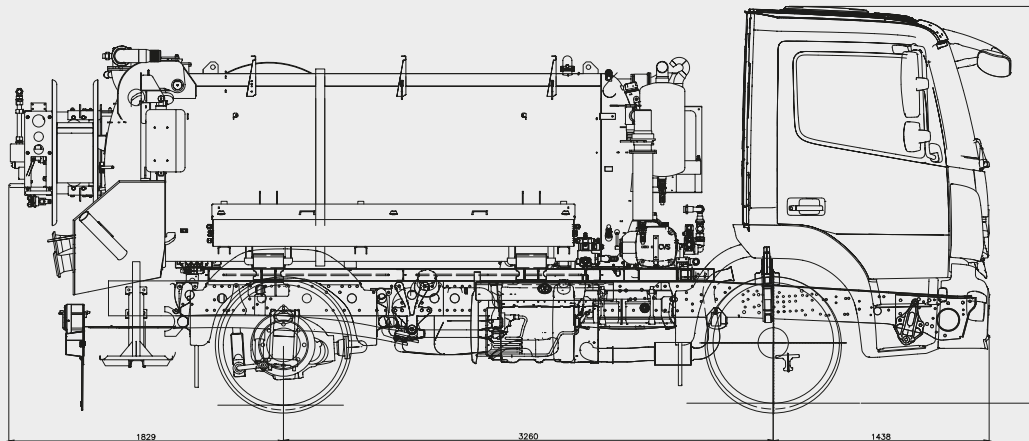

Dimensions and weight*

Length	6,527 mm
Width	2,400 mm
Height	2,641 mm
Wheelbase	3,260 mm
GVW	13,500 kg
TARE weight	Approx. 6,600 kg

Transmission

Power take-off	From gearbox
Jetting pump	Hydraulic driven
Vacuum pump	Hydraulic driven

Engine

Type	M1K
Horse power	231 HP
Emission level	Euro 6
Fuel	Diesel

Chassis**

MB Atego	1323K 4x2
Cab type	S-Cab
Mudguards	Plastic
Cyclist protection	One on each side
Protective grilles	On rear lights

Finish

Undercarriage and components	Grey
Cabin/Tank	White
Cabinets and shelves	Aluminium
Paint	Corrosion class C3
Tank: 200-300 µm	Rest: 100-120 µm
Text and stripping	Invoiced separately

* Depending on selected chassis and/or optional equipment.

** Chassis mentioned is just one example.

For all small-scale jetting and vacuum tasks in densely populated areas



Control panel

Intuitive operation thanks to the control panel and remote control.



Handwash facility (option)

Keep hygiene on top. Wash your hands with clean water (cold/warm).

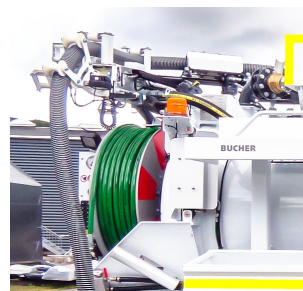

Suction cassette (option)

Enjoy the practical suction hose w. telescope extension up to 2 m.



Storage

Store your gear safely in the lockable cabinets.

Bucher CityFlex C40

Tank

Volume	3.8 m ³
Operating pressure	0.5 bar
End cover	Hydraulic, fully automatic

A hydraulically moved partition divides the tank in two variable water/sludge volume compartments.

Tank level indicator	2, sludge & water
Suction valves top	3", pneumatic
Suction valves bottom	4", manual
Water filling valve	2"

High-pressure system

Pump model	Uraca P3-10
Pump capacity	127 l/min @ 160 bar
Hose size	¾" 150 m
Hose material	Plastic
Jetting hose reel rotation	Hydraulic
Jetting hose reel swing	Manual

Vacuum system

Pump model	CVS RSL 400
Pump type	Air cooled w. lubrication
Pump capacity	203 cfm (5,750 l/min)
Transport reel	Hydraulic
40 m 3" suction hose split in three lengths	

Controls

Controller	CAN bus
Control panels	1 pcs.
Remote control (14 functions)	1 pcs.

Storage

Cabinets	2 pcs.
Shelves	2 pcs.

Lights

Work lamps	1 pcs., LED
Beacon lights	2 pcs., LED

Frost protection

Air pressure draining and cleaning - incl. blow out air hose

Accessories

- One nozzle set

Options*

- One vice
- One cone holder
- One cover hook holder
- One handwashing facility (warm water)
- Three storages for safety fence
- 12 V socket, incl. 24-12 V converter
- 3" suction cassette
- Dewatering mesh, top suction
- Red chevron on hose reel, one side
- One cover hooks set (6 pcs.)

- One coupling adaptor 3" to 3"
- One coupling adaptor 3" to 4"
- One 1.75 m 4" hose for unloading
- One end cover safety support

*Additional cost

Contact us for more information.

Bucher Municipal



For local contact and support, please scan the QR code or visit

buchermunicipal.com

Driven by better



Bucher Municipal E-Shop

Version 01_05_2023
 Technical data is subject to change without prior notice.
 The illustrations may deviate from standard equipment.