

# Bucher CityCat VR50

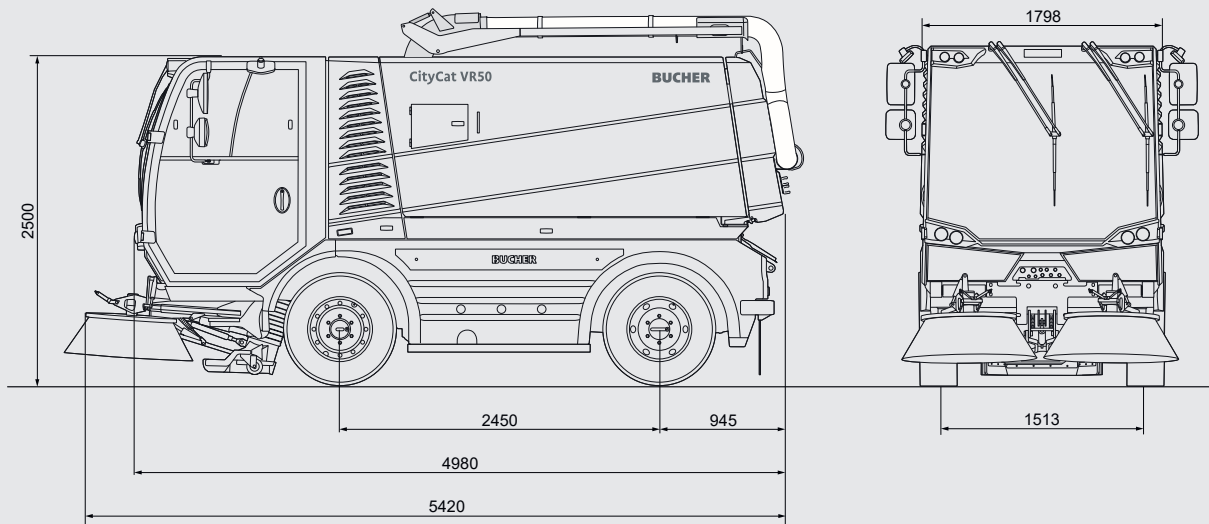

## Dimensions

Length	4980 mm
Width	1798 mm
Height	2500 mm
Wheelbase	2450 mm
Track width	1513 mm
Cleaning width	2533 mm
Turning radius	2950 mm

## Tyres

265 / 70 R 19.5 140 / 138M

\* According to national legislation

## Driving Performance

Working speed	0-20 km/h
Travelling speed	0-80 km/h*
Climbing ability	up to 30 %

## Noise level cab

63 dB(A)

## Chassis

Bucher fabricated ladder frame chassis with "C" Rail construction

GVW	10 400 kg (80 km/h)
Empty weight	5500 kg (80 km/h)
Payload	4900 kg (80 km/h)

## Engine Euro 6

FPT, Iveco Euro 6	NEF 4 Euro VI
Engine displacement	4485 cm <sup>3</sup>
Output	118 kW
Torque	580 Nm
AdBlue tank	30 l

## Bucher CityCat VR50: performance package in the compact class

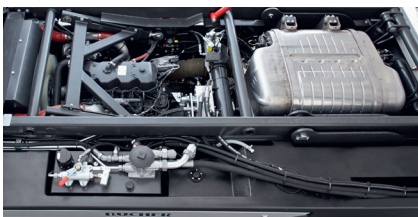

### Low-emission Engine Euro 6

The smooth-running, high-torque Iveco Euro 6 diesel engine with extremely low fuel consumption and emission levels allows exceptionally reliable and economical operation.



### Choose your settings

The CSense display (10.1 inch touch display) with intuitive design for extended functions, central overview of all settings and visual diagnostic system. The displayed vehicle set-up can be individually chosen by the driver.

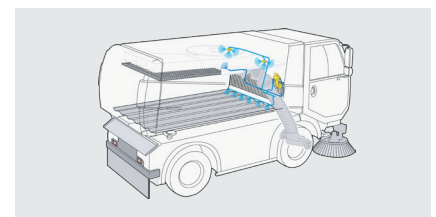

### EasyClean System

The operator simply activates the EasyClean self-cleaning function. The blower, filter screen, dirty water tank, side walls and other difficult to reach pockets of dirt are then sprayed by the cleaning nozzles. The machine is perfectly clean within a couple of minutes.

# Bucher CityCat VR50

## Steering

Hydrostatic controlled four wheel steering.

## Axles

Drive-axle at the rear with differential and planetary hub reduction. Running axle at the front.

## Hydraulic

The latest electronic control concept makes it possible to control the diesel engine in terms of optimal consumption and noise for a hydrostatic drive over the entire speed range. Without compromising on performance.

Diesel consumption and exhaust pollutant emissions have been greatly reduced thanks to the electronic control concept and the Euro 6 diesel engine. Valuable resources and the entire vehicle system are protected. Test drives have resulted in diesel savings of 30 % as well as a 20 % noise reduction when passing by in road travel mode. On top of that, the positive effect can also be seen in the operating costs.

## Brakes

Hydraulic, dual-circuit high performance brake system with double callipers on each side on front axis and single calliper on rear axis. Manually operated parking brake, acting hydraulically on additional brakes disc ahead of differential.

## Driver's cab

Comfortable, hydro bearing suspension, soundproofed cab. Windscreen made of heat-insulating, curved, low-reflection safety glass. 2 sliding windows in each door. Multi-speed heating fan. Sun visor. Air conditioning system. Windscreen wiper/washer system. Air sprung driver's seat and sprung passenger's seat, each individually adjustable. Steering column can be adjusted in both the angle and height. CSense display (10.1 inch touch display) with intuitive design for extended functions, central overview of all settings and visual diagnostic system. The displayed vehicle set-up can be individually chosen by the driver

## Pick-up system

Pick-up principle based on suction, with retracted, rust-proof suction nozzle in front of axis, can be hydraulically moved 400 mm laterally with the side brush. Hydraulic suction nozzle height adjustment. Stepless adjustable high-power suction fan.

## Hopper

Volume	5.6 m <sup>3</sup>
hydraulic tipping and opening.	
Dumping height, low dumping	930 mm
Dumping height, high dumping	1550 mm
Dumping width	1700 mm
Tipping angle	51 °

## Water system

Water capacity	880 l
Water pump for water nozzles.	

## Brushes

2 side brushes left and right	Ø 900 mm
Impact-proof brush suspension - impact protection	
Variable speed adjustment	0-150 rpm

## Options

- Additional water tank 1120 l (total 2000 l - reduces hopper volume)
- Boom with reel and hand lance
- Water recirculation system
- Wander hose
- Water flushing bar
- EasyClean system
- Rear view and suction nozzle camera
- Data capture

A variety of other options are available – contact us for more information.

## Bucher Municipal



For local contact and support, please scan the QR code or visit

[buchermunicipal.com](http://buchermunicipal.com)

Driven by better



Bucher Municipal  
E-Shop