

Bucher CityCat WR50e

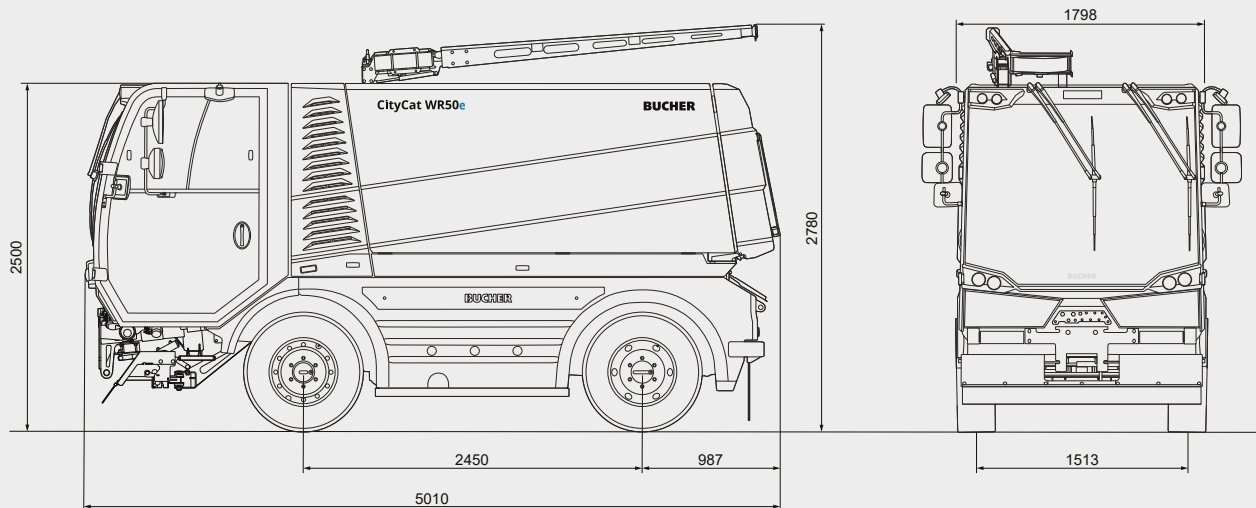

Dimensions

Length	5010 mm
Width	1798 mm
Height	2500 mm
Height with boom	2780 mm
Wheelbase	2450 mm
Track width	1513 mm
Cleaning width min.	2250 mm
Cleaning width max.	3670 mm
Turning radius	2950 mm

Tyres

265 / 70 R 19.5 143 / 141J

Driving Performance

Working speed	0-20 km/h
Travelling speed	0-50 km/h*
Climbing ability	up to 21 %

Noise level

92 dB(A)

Chassis

Bucher fabricated ladder frame chassis with "C" Rail construction	
GVW	10 500 kg*
Empty weight	5750 kg
Payload	4750 kg

HV Battery

Battery type	Li-ion
Battery capacity	137 kWh
Nominal voltage	573 Volt
Operating time	up to 10 hours

Charging system

On-board charger	22 kW
Charging time	5 to 6 hours
External charger DC ¹	70 kW
Charging time	1.5 to 2 hours

* According to national legislation

¹ Option

Bucher CityCat WR50e: the efficient high-capacity washer



Charging anywhere, anytime

Charging with both AC 22 kW and DC 70 kW allows full flexibility and customization to individual needs. From single shift to multiple shifts, and charging time of up to two hours.



Hydrostatic controlled four wheel steering

The compact outer dimensions, as well as the four-wheel steering that can be turned on and off, give the vehicle maximum manoeuvrability and ensure perfect directional stability and safety for everyday work.



Boom with hose reel and hand lance

The hand lance and water hose with a length of 15 m and an automatic reel are attached to a boom mounted on top of the washer and allow 360° cleaning around the vehicle.

Bucher CityCat WR50e

Steering

Hydrostatic controlled four wheel steering.

Axles

Drive-axle at the rear with differential¹. Running axle with coil springs and shock absorbers at the front.

Working hydraulics

Electrically driven hydraulic unit with low-noise gear pumps for steering, auxiliary functions and operation of the spray bar¹.

Washing system

The height of the spray bar mounted underneath the cab can be adjusted and swivelled to the left or right. The installation position under the cab enables the additional attachment of front-mounted equipment. The washing system is designed for optimum cleaning performance and low water consumption.

Driver's cab

Comfortable, hydro bearing suspension, soundproofed cab. Front windscreen made of heat-insulating, curved, low-reflection safety glass. Sliding windows in each door. Multi-speed heating fan. Sun visor. Windscreen wiper/washer system. Individually adjustable, air-sprung driver's seat with headrest and 3-point seat belt. Angle and height-adjustable steering column.

Control unit

Smart-Con operation concept includes a multi-functional armrest with Smart-Start Function which makes it possible to operate all working functions with one hand. All relevant information at a glance at any time thanks to the digital 4.3 inch display. CSense display (10.1 inch touch display) with intuitive design for extended functions, central overview of all settings and visual diagnostic system.

Water tank

Main water tank made of corrosion-resistant stainless steel 1.4301, with baffle plate and two low-lying plastic side tanks for a low centre of gravity and good driving stability. The water tank can be tilted hydraulically for easy maintenance.

Volume up to 5000 l

Boom with hose reel and hand lance

The booms are equipped with an automatic 15 metre hose reel and a hand lance each. These can be rotated 360° and are supported by gas pressure springs. The changeover valve enables switching between the installed high-pressure pumps (100 bar / 200 bar¹).

Water system

The pump is switched off automatically if there is a lack of water. The water is filtered twice. The pressure can be adjusted from the cab.

Max. flow rate 142 l/min

Max. pressure 100 bar

Drive electric motor

Brakes

Hydraulic, dual-circuit high performance brake system with double callipers on each side on front and single calliper on rear axis. Spring-loaded brake, acting on the rear axle.

Options

- Standard spray bar
- Telescopic spray bar
- High pressure water pump 200 bar
- 2nd boom with automatic 15 m hose and hand lance
- External charging with DC 70 kW
- Hand lance supports rear
- Water meter (for filling) with visualisation in the work display and integration in Data Capture & Bucher Connect

A variety of other options are available - contact us for more information.

¹Option

Bucher Municipal



For local contact and support, please scan the QR code or visit

buchermunicipal.com

