

# Bucher CityCat VR50e

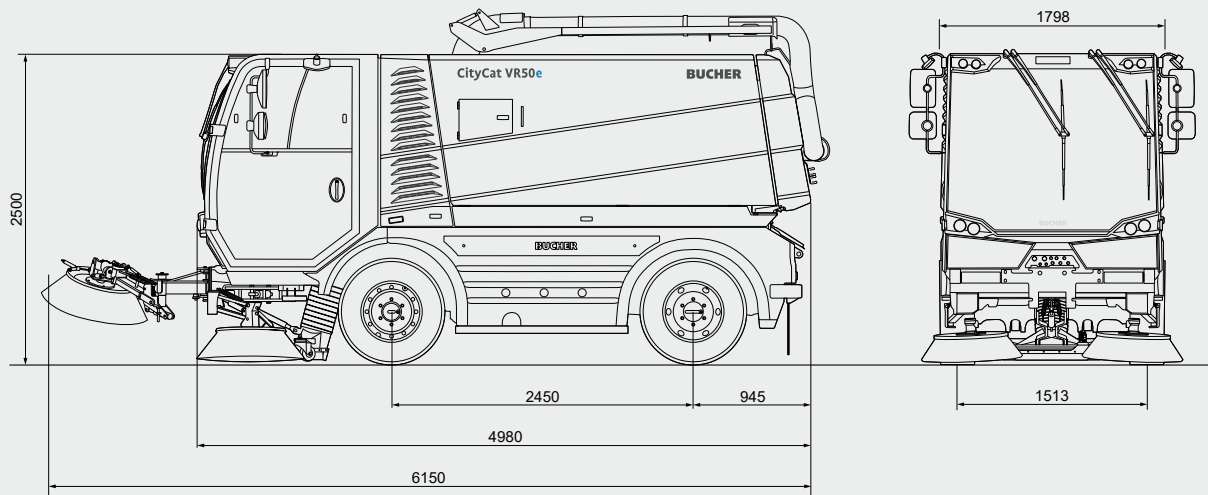

## Dimensions

Length	4980 mm
Width	1798 mm
Height	2500 mm
Wheelbase	2450 mm
Track width	1513 mm
Cleaning width 2 brushes	2533 mm
Cleaning width 3 brushes	3520 mm
Cleaning width 3 brushes (RCB)	3768 mm
Turning radius	2950 mm

## Tyres

265 / 70 R 19.5 143 / 141J

## Driving Performance

Working speed	0-20 km/h
Travelling speed	0-50 km/h*
Climbing ability	up to 30 %

## Noise level

92 dB(A)

## Chassis

Bucher fabricated ladder frame chassis with "C" Rail construction

GVW	10 500 kg
Empty weight	5800 kg
Payload	4700 kg

## HV Battery

Battery type	Li-ion
Battery capacity	137 kWh
Nominal voltage	573 Volt
Operating time	up to 10 hours

## Charging system

On-board charger	22 kW
Charging time	5 to 6 hours
External charger DC <sup>1</sup>	70 kW
Charging time	1.5 to 2 hours

\* According to national legislation

<sup>1</sup> Option

## Bucher CityCat VR50e: performance package in the compact class



### Charging anywhere, anytime

Charging with both AC 22 kW and DC 70 kW allows full flexibility and customization to individual needs. From single shift to multiple shifts, and charging times of up to two hour.



### Choose your settings

The CSense display (10.1 inch touch display) with intuitive design for extended functions, central overview of all settings and visual diagnostic system. The displayed vehicle set-up can be individually chosen by the driver.

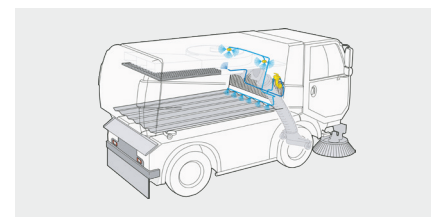

### EasyClean System

The operator simply activates the EasyClean self-cleaning function. The blower, filter screen, dirty water tank, side walls and other difficult to reach pockets of dirt are then sprayed by the cleaning nozzles. The machine is perfectly clean within a couple of minutes.

# Bucher CityCat VR50e

## Steering

Hydrostatic controlled 4 wheel steering.

## Axles

Drive-axle at the rear with differential and planetary hub reduction. Running axle at the front.

## High capacity battery Pack

Battery pack with 137 kWh. This guarantees an outstanding autonomy with an operating time of up to 10 hours with a single charge. The exceptionally robust and maintenance-free design provides a long service life and a minimized battery aging.

## Charging System

Two charging systems for all situations	
Internal Charger	22 kW
Charger Inlet	Type 2
Charging time 137 kWh	5 - 6 hours
External Charger DC	70 kW
Charging Inlet	CCS Combo 2
Charging time 137 kWh	1.5 - 2 hours

## Brakes

Hydraulic, dual-circuit high performance brake system with double callipers on each side on front axis and single calliper on rear axis. Manually operated parking brake, acting hydraulically on additional brakes disc ahead of differential.

## Driver's cab

Comfortable, hydro bearing suspension, soundproofed cab. Windscreen made of heat-insulating, curved, low-reflection safety glass. 2 sliding windows in each door. Multi-speed heating fan. Sun visor. Windscreen wiper/washer system Air-sprung driver's seat and sprung passenger's seat, each individually adjustable. Steering column can be adjusted in both the angle and height. CSense display (10.1 inch touch display) with intuitive design for extended functions, central overview of all settings and visual diagnostic system. The displayed vehicle set-up can be individually chosen by the driver.

## Pick-up system

Pick-up principle based on suction, with retracted, rust-proof suction nozzle in front of axis, can be hydraulically moved 400 mm laterally with the side brush. Hydraulic suction nozzle height adjustment. Stepless adjustable high-power suction fan.

## Hopper

Volume	5.6 m <sup>3</sup>
hydraulic tipping and opening.	
Dumping height, low dumping	930 mm
Dumping height, high dumping	1550 mm
Dumping width	1700 mm
Tipping angle	51 °

## Water system

Water capacity	880 l
2 water pumps for water nozzles.	

## Brushes

2 side brushes left and right	Ø 900 mm
Impact-proof brush suspension - impact protection	
3rd front brush on Type XL for maximum cleaning width of 3520 mm, can be used left and right	
Variable speed adjustment	0-150 rpm

## Options

- Air conditioning
- External Charger DC 70 kW
- Additional water tank 1120 l (total 2000 l - reduces hopper volume)
- Boom with reel and hand lance
- 100 bar or 200 bar water pump
- High dump
- Water recirculation system
- Wander hose
- Weed brush
- Hydraulic tilt of the side brushes
- Water flushing bar
- High pressure water system
- EasyClean system
- Gutter guard lifting gear
- LED work light
- Rear view and suction nozzle camera

A variety of other options are available - contact us for more information.

## Bucher Municipal



For local contact and support, please scan the QR code or visit

[buchermunicipal.com](http://buchermunicipal.com)

Driven by better



Bucher Municipal  
E-Shop